

07	MOTORE	D58 HI2 cl F	1
06	FILORES.	ALKROTHAL	
05	VENTOLA	ALL. 2 PALE CHIARA	1
04	SUPPORTO TV115/N	NYLON	1
03	W1 - W2 6.3 X 0.8	FE.ST.	2
02	W0 6.3 X 0.8	FE.ST.	1
01	TERMOSTATO	TH11 70° PTC	1
POS.	DENOMINAZIONE	MATERIALE	Q. TA

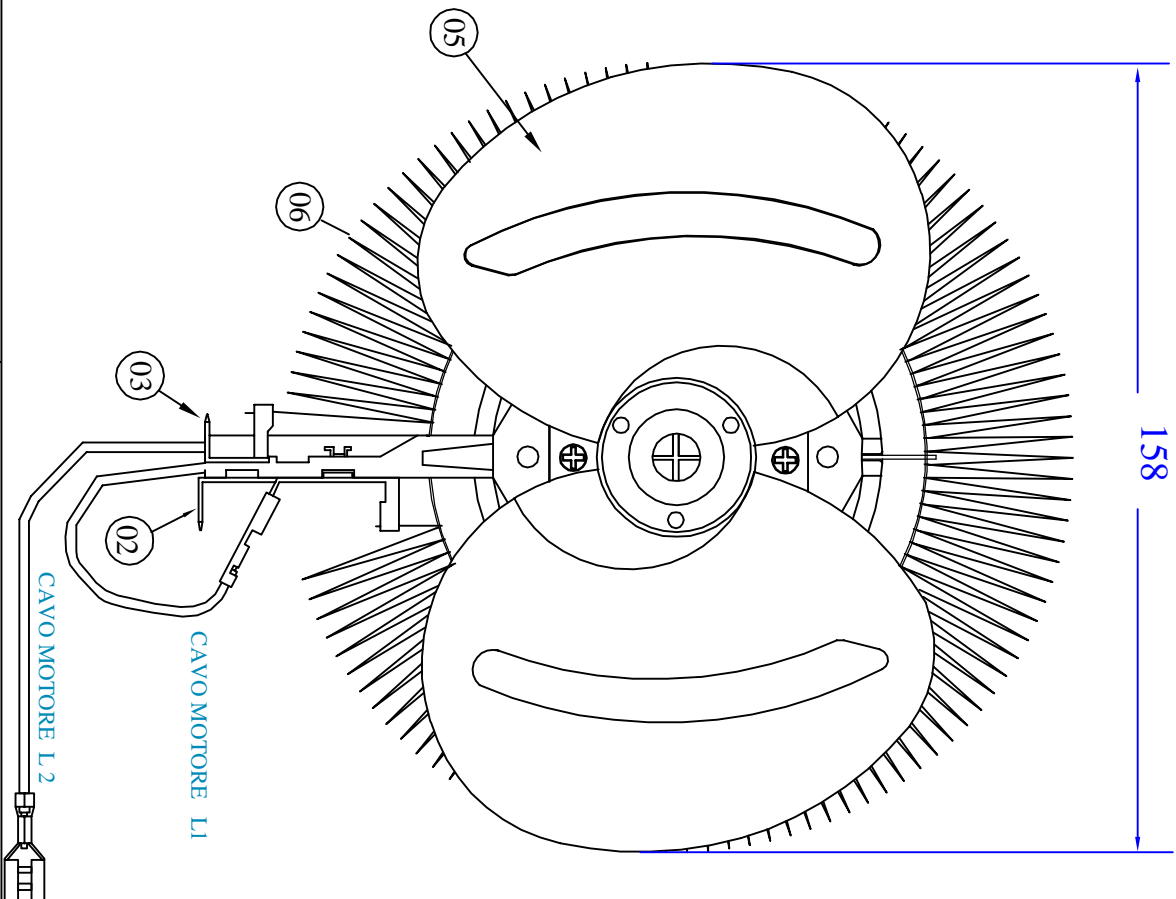
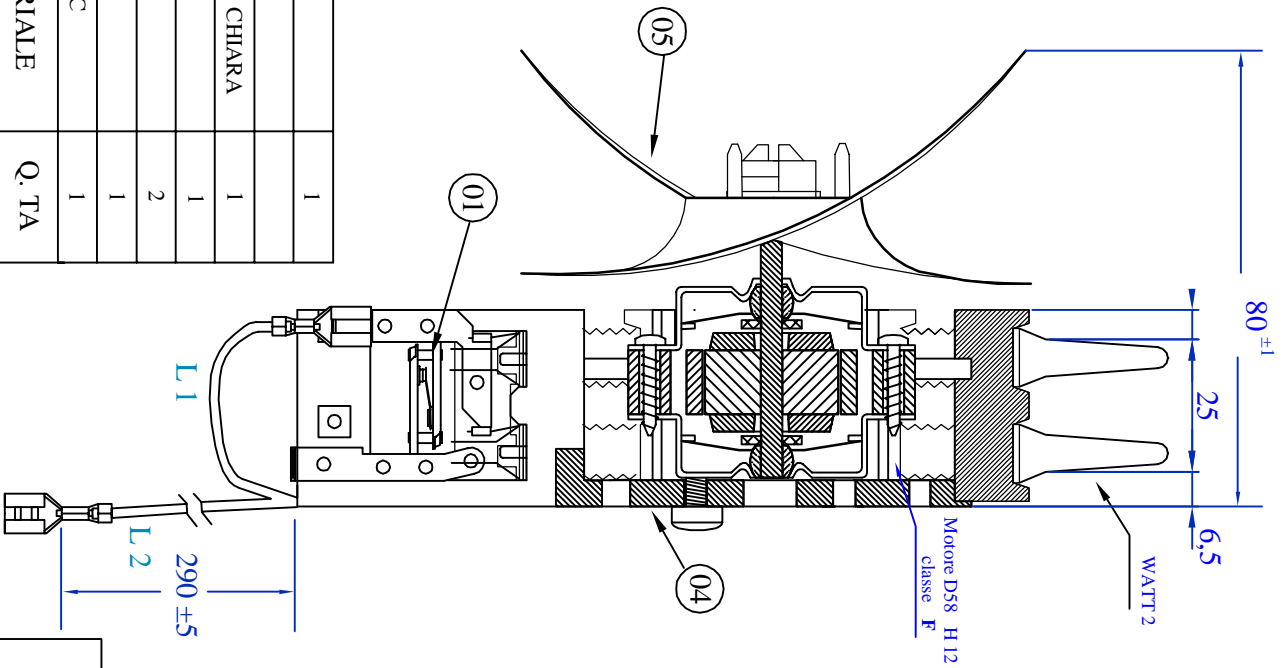

FREITECH

GRUPPO TV115/N

DENOMINAZIONE: